

OMEPHA ALEMANIA MÉXICO
Fuente de la Lluvia 263
Colonia Balcones de Valle
78280 San Luis Potosí, S.L.P., México

Tel (444) 820 5465
Cel (444) 104 1350
info@omepha-alemania-mexico.com
www.omepha-alemania-mexico.com

Manual

Solutions





The Torque Multiplier Series LKV, 4,000-54,000 N·m

Series LKV-40 to 540RS

Integrated return safety „RS“ for
CW/CCW rotation and safe opera-
tion (as of model LKV-40RS)



Integrated overload safety mecha-
nism for gear unit protection

Lean, high-performance alumi-
num housing is 30% lighter than a
steel one

Planet gear unit with ceramic-
Teflon®-coated tooth flanks (as of
model LKV-40) enables minimum
lubrication

Drop-forged reaction arm with
lock on function, made of chrome-
vanadium steel for even greater
stability



Supplied with individual LÖSOMAT
factory calibration certificate



Reinvented: The torque multiplier

The torque multiplier is probably the simplest device in high level torque bolting technology and has been around for over forty years.

LÖSOMAT has reinvented this proven tool. With a clever design and new functions, the new torque multiplier series is a great contribution to facilitating operations.

Housing and gear unit

The housing and gear unit are the innovations in this series. A new production method was created, based on nature. The housing is therefore approx. 30% lighter but still as rugged.

At the same time, the ceramic-Teflon® coating enables minimum device lubrication. While conventionally lubricated torque multipliers decrease in performance (efficiency) when the outside temperatures are colder, due to the increasing tenacity of the grease, this unit operates independently of the temperature.

Reaction arm

The reaction arm, which must resist the counter-forces during bolting operations, has also been completely re-worked.

Force distribution was analysed using complex FEM methods. It is therefore even more stable and durable than before due to the shape and materials selected.

In addition, the reaction arm is equipped with a patented hold function that prevents the gear teeth from slipping.

Non-destructive overload protection

The 40-550RS models are equipped with a non-destructive overload safety mechanism.

This patent-filed innovation represents real cost savings for the user.

The basis of this extra feature is a highly-dynamic, pre-tensioned slip-coupling.

As soon as the maximum permissible input torque is exceeded, the „Slipper“ triggers with a clearly audible acoustic noise.

The torque multiplier is not damaged so that normal operation can be started again. This means that no assembly downtimes occur and the safety of the operator is actively supported.

Certified safety

A completely new benefit for the torque multiplier is the individual factory calibration certificate for each device. This has never been the case before.

This allows bolting operations to be implemented at a high level of torque precision.

The torque tables on the devices display the standard torque for HV bolts.

The tables can also be modified on request to the individual torques of the operator.





Accessories for the LKV-40 to LKV-120RS



Reaction arm cranked with lock on function, made of drop-forged chrome-vanadium steel (up to LKV-80)



Reaction arm cranked with lock on function, made of light alloy with protective cap made of steel (from LKV-100)



Reaction arm made of light alloy, straight with adjustable locking knob with moveable square-end and retaining ring (up to LKV-100)

More information on Page 48.

Technical data LKV-40 - 550RS

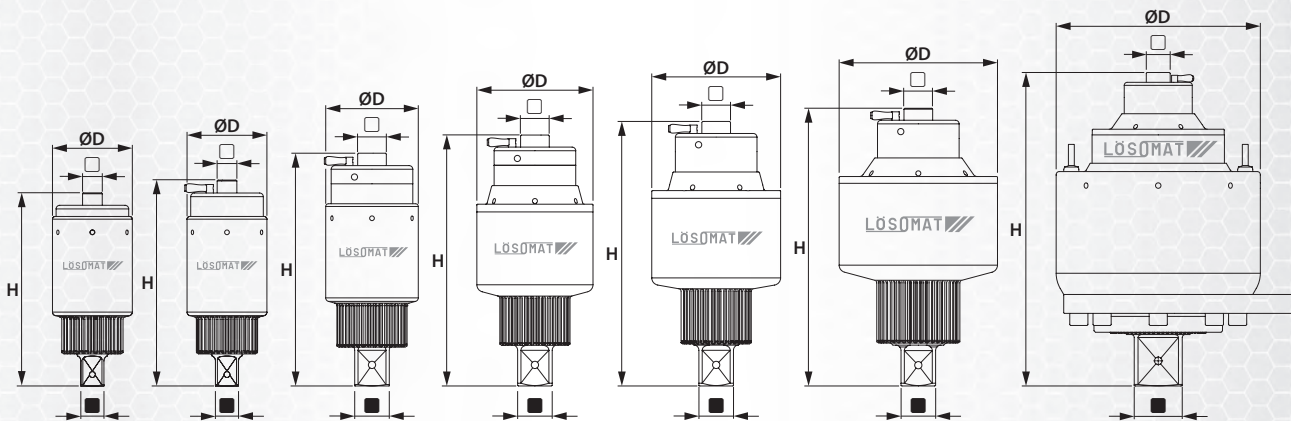

LKV-40

LKV-40RS

LKV-60RS

LKV-80RS

LKV-100RS

LKV-120RS

LKV-550RS

Type	N·m max	lbf·ft max	N·m min / max* ¹	lbf·ft min / max* ¹	* ²			Ø D mm	H mm	* ³
LKV-40	300	220	500-4000	400-2930	1:16	½"	1"	88	212.8	3.9
LKV-40RS	310	230	500-4000	400-2930	1:16	½"	1"	88	226.9	4.2
LKV-60RS	400	300	650-6000	500-4400	1:18	¾"	1 ½"	102	256.2	6.6
LKV-80RS	420	310	800-8000	600-5870	1:22	¾"	1 ½"	128	276.5	9.1
LKV-100RS	410	305	1000-10000	700-7330	1:28.5	¾"	1 ½"	142	291.5	10.9
LKV-120RS	380	280	1320-13000	1000-9530	1:39	¾"	1 ½"	174.5	306	17.0
LKV-550RS	380	280	5500-54000	4000-40330	1:175	¾"	2 ½"	270	414.5	64.6

*1 Maximum load limit! Take into account a reserve of ~25% when selecting a device and, where applicable, note increased loosening torques!

*2 Approximate data *3 Without reaction arm (except for LKV-550RS device with reaction plate)

All rights reserved. Subject to modifications without prior notice.



The function principle



The principle of torque multiplication

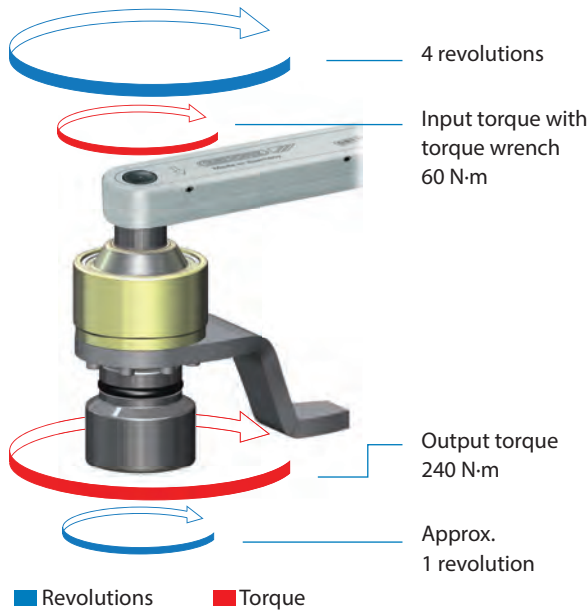

The chart representation demonstrates the principle of torque multiplication.

Let us assume a 60 N·m input torque and a 240 N·m output torque. At a 1:4 ratio, 4 revolutions are needed at the input for 1 revolution with a 240 N·m torque to be obtained at the output. This is based on the physical formula:

Power = torque x revolution

With gear efficiency deducted, the output power can be considered as a constant equal to the input power. Thus multiplication of the torque can only be obtained from an increased number of revolutions at the input.



Force and reaction

When working with a torque multiplier, torsion wind-up is built up in the gear while the bolt is tightened. This stress must be reduced. A reaction absorbed by reaction arm and thrust bearing is produced.

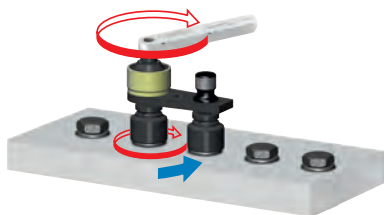

Reaction arm made of light alloy, straight with adjustable locking knob with slave square: The reaction acts on the adjacent impact socket

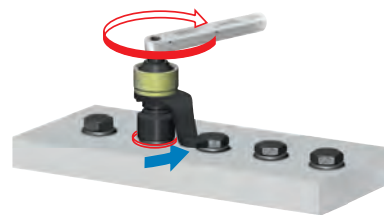

Reaction arm cranked: The reaction acts on the adjacent bolt connection

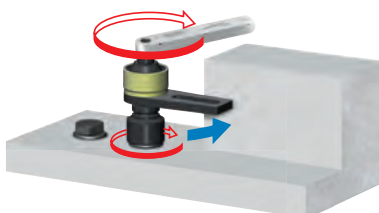

Reaction arm straight without adjustable reaction square drive: The reaction acts on the wall. However, the resulting tilting moment means that the maximum permitted torque is reduced by 20%.





Reaction arm made of light alloy, straight with adjustable locking knob with movable square-end



Reaction arm with adjustable locking knob

Reaction square can be released and shifted horizontally. This means the reaction arm can be adapted to the various flange screw fittings.

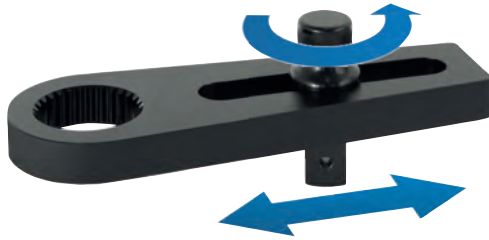

The torque multiplier in tests

Our torque multipliers are tested to their limits.

Thanks to temperature and load tests, we can make statements about bolting operations in various climate zones and about the robustness and durability of the device.

Cold test:

The ambient temperature always has an influence on the degree of efficiency and therefore on the accuracy of the device. The torque multiplier was cooled to -40°C in a cold test. Due to the minimal lubrication in the planetary gearing, the temperature influence could be kept to a minimum and the device could be used as usual.

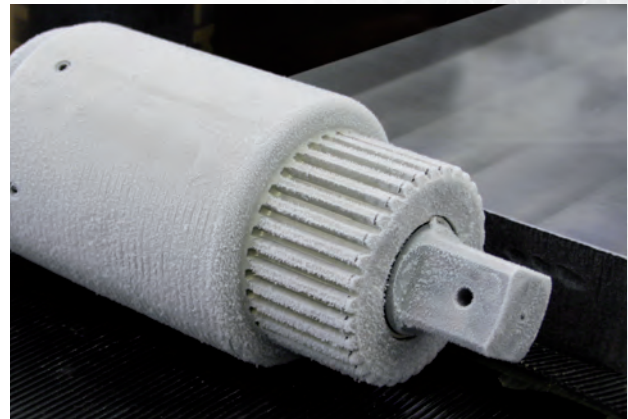

LKV cooled down to -40°C

Load test:

If a torque multiplier is overloaded, there is no danger to the gearing. The square drive of the device has a predetermined breakaway point. Wird ein Kraftvervielfältiger überbelastet, besteht keine Gefahr für das Getriebe. Der Antriebsvierkant des Geräts ist mit einer Sollbruchstelle ausgestattet und schert sauber ab, wenn zu viel Belastung auf das Gerät einwirkt. Der abgescherte Antriebsvierkant kann problemlos ausgetauscht werden. Der Vorteil daran ist, dass keinerlei Splitter oder Verbiegungen beim Abscheren entstehen. Somit bleibt das Gerät funktionsfähig.

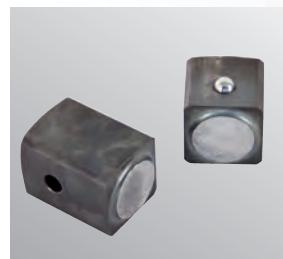

LÖSOMAT:
Controlled breakaway



OTHERS:
Uncontrolled breakaway can damage other components



The mobile LKV App



You can now get the...

LKV Torque Calculator on your Smartphone.

FREE

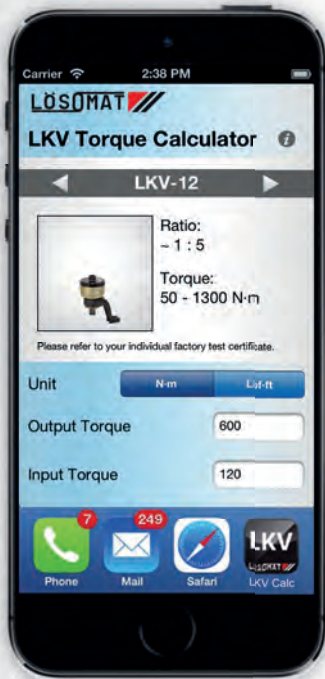

No mental arithmetic anymore!

With this App you get at the push of a button your required input torque. You work with a Torque Multiplier of the LKV series and you know the output torque but not how to calculate the input torque? Then get easy the input torque with this App.

- ✓ calculation of input torque
- ✓ Unit: N·m and Lbf·ft
- ✓ in 11 languages available
- ✓ Warning function in case of too high or low torques
- ✓ For iPhone (from iOS 4.3)
- ✓ For Android (from 2.2)





The Torque Multiplier Series LKV, 50-1,300 N·m

Series LKV-12

Lean, high-performance aluminium housing is 30% lighter than a steel version

Total weight of 1.9 kg for best torque-weight ratio

Easy to handle and compact as optimal on-board tool suitable for utility vehicles or construction machines

Drop-forged reaction arm with lock on function, made of chrome-vanadium steel for even greater stability



Supplied with individual LÖSOMAT factory calibration certificate

Accessories for the LKV-12



Reaction arm cranked with lock on function, made of drop-forged chrome-vanadium steel



Reaction arm made of light alloy, straight with adjustable locking knob with slave square and retaining ring
More information on Page 48.



Sun gear



Technical data LKV-12



Small, easy to handle, light but rugged

The smallest torque multiplier in this series is particularly suitable for maintenance purposes and in workshops.

The little power packet has been reduced to the smallest possible dimensions without losing any robustness or torque power.

It is equipped with an offset reaction arm and can be retrofitted with a straight reaction arm.

The sun gear acts as a predetermined breaking point if the device is overloaded. This protects both the operator and the device. The sun gear can be easily and rapidly replaced by the operator. Assembly and cost outlay remain low.

The optimal on-board tool

The LKV-12 has small dimensions and can fit in a pocket.

This device is highly suitable for use as an on-board tool in utility or construction site vehicles.

It can be stored in the vehicle in a stable transport case. Due to the minimum lubrication of the gear unit, the device is essentially temperature-independent and can be operated without problems even at freezing temperatures.

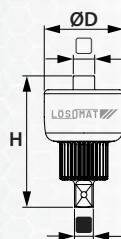

Type	N·m max	lbf·ft max	N·m min / max*1	lbf·ft min / max*1	*2			Ø D mm	H mm	*3
LKV-12	270	200	50-1300	40-950	1:5	1/2"	3/4"	80	132.5	1.3

*1Maximum load limit! Take into account a reserve of ~25% when selecting a device and, where applicable, note increased loosening torques!

*2 Approximate data

*3 Without reaction arm

All rights reserved. Subject to modifications without prior notice.

The Torque Multiplier Series LKV, 500-2,800 N·m

Series LKV-20/28Z

Lean, high-performance aluminium housing is 30% lighter than a steel one



Fixed reaction arm in straight or cranked version

Output square as overload protection for gear unit protection



Supplied with individual LÖSOMAT factory calibration certificate

Series LKV-20/28-L



Accessories for the LKV-20 and LKV-28



Reaction arm cranked (bolted to the tool)



Reaction arm made of light alloy, straight with adjustable locking knob with reaction slave square (bolted to the tool)

More information on Page 48.



Spare square for LKV-20

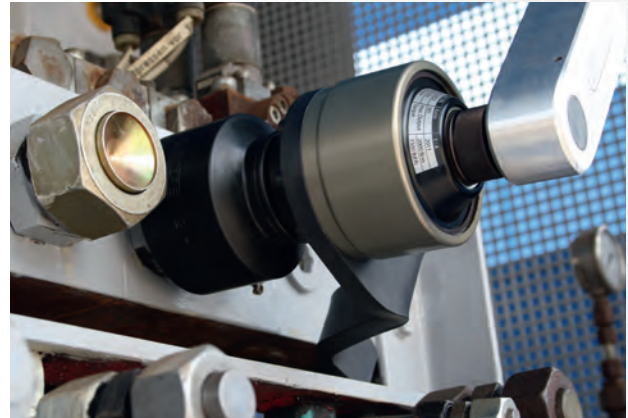

Spare square for LKV-28

**Technical data LKV-20L/Z and LKV-28L/Z****Popular for flange bolt connections:
LKV-20/28L**

The positioning of the torque multiplier must be implemented easily and rapidly, particularly for flange bolt connections.

The LKV-L is equipped with a fixed straight reaction arm and is therefore a complete solution for flange bolt connections.

The required spacing between two bolts can be rapidly and easily set using the adjustable reaction square, accelerating work.

Practical and easy to handle: LKV-20/28Z

The LKV-Z series is particularly suitable for mechanical and plant engineering, maintenance and the transport industry.

This series also has a fixed reaction arm, but cranked version.

The gear unit is protected against overload with a shearing square which can be easily replaced.

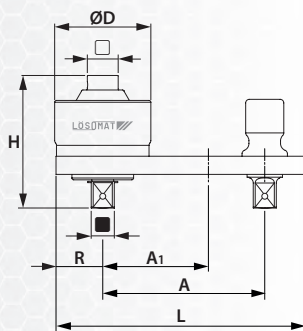

LKV-L

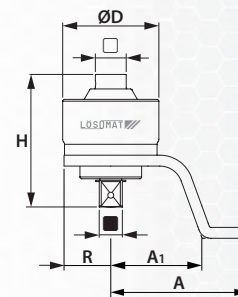

LKV-Z

Type	N-m max	lbf-ft max	N-m min / max*1	lbf-ft min / max*1	*2			A mm	A ₁ mm	Ø D mm	H mm	R mm	kg *3
LKV-20L	580	430	100-2000	70-1500	1:4	¾"	1"	152	73	88	131	43	1.8
LKV-20Z	580	430	100-2000	70-1500	1:4	¾"	1"	150	100	88	131	43	1.8
LKV-28L	550	410	500-2800	400-2050	1:5.5	¾"	1"	199	83	106	146	52	2.4
LKV-28Z	550	410	500-2800	400-2050	1:5.5	¾"	1"	151	101	106	146	52	2.4

*1 Maximum load limit! Take into account a reserve of ~25% when selecting a device and, where applicable, note increased loosening torques!

*2 Approximate data *3 Without reaction arm

All rights reserved. Subject to modifications without prior notice.



The Counter Wrench LKS series, RSW 32 - 115 mm

LKS series

Rugged housing
made of cast steel

The allen screw fixes the ring
wrench inserts and enables **simple
and rapid replacement**

Pivoted reaction arm
adjusts to the most diverse envi-
ronments
Can also be used without reaction
arm

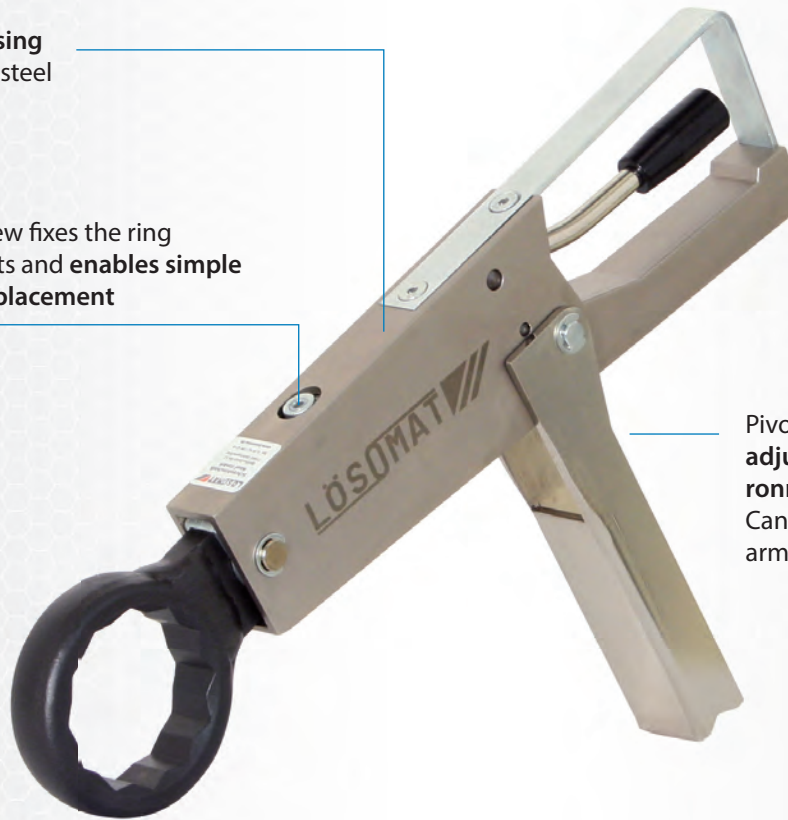

Various ring wrench inserts enable
universal holding up

Accessories

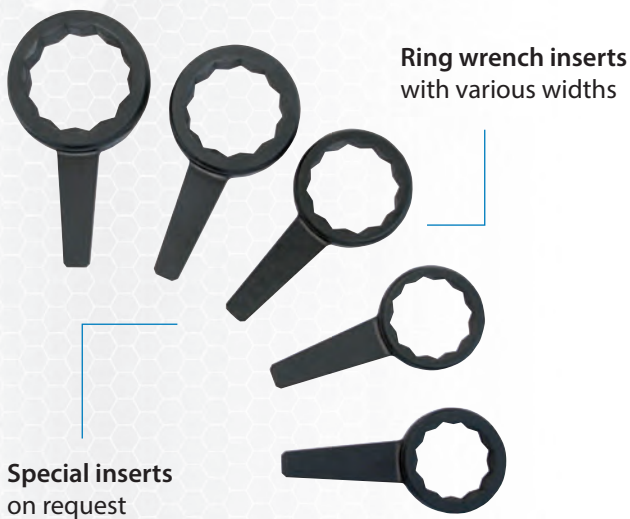



Danger to assembly personnel must be avoided

Every user knows the problems and dangerous situations that can arise when counter-holding while a bolted connection is being tightened. The wrench used for counter-holding can often rotate with unpredictable torques, block or jump off. Once the bolting operation is complete, it often needs to be levered off or even knocked off. The danger of injury for the assembly personnel is very high here and the risk of damaging neighbouring components or the tools is also significant. The results can be irritation, time loss and assembly downtimes.

The solution: The LÖSOMAT Counter Wrench

Equipped with the appropriate insert, the device utilises a thrust bearing and absorbs the driving torque with the integrated mechanics. Following completion of the bolting operation, a simple press of the lever and the counter-wrench can be rapidly and easily released.

Frequently copied, but never matched

The patented mechanism of the LÖSOMAT counter wrench is unique. Only the precise interplay of the individual components ensures correct and problem-free function. Cheaper copies can bend or stick under large loads. The ring inserts are made of forged chrome-vanadium steel as of size 70.

Technical data

Type	L ₁ mm	B ₁ mm	H ₁ mm	L ₂ mm	B ₂ mm	H ₂ mm	⚖️
LKS	310	27	65/95	190	38	30	2.6 / 0.4 ^{*1}

*1 plus reaction element

Ring wrench inserts type RSW

RSW mm	Ø ^{*2} mm	RSW mm	Ø ^{*2} mm	RSW mm	Ø ^{*2} mm
32	54	60	94	90	152
36	54	65	104	95	152
41	60	70	110	100	155
46	75	75	115	105	172
50	80	80	126	110	172
55	88	85	130	115	172

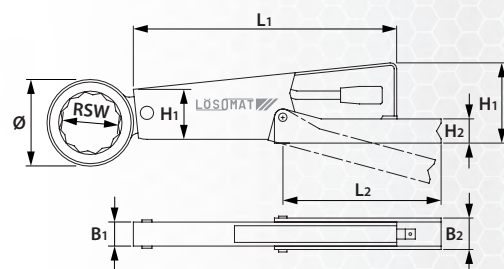

*1 Head diameter (Ø similar DIN 7444).

All rights reserved. Subject to modifications without prior notice.