

OMEPHA ALEMANIA MÉXICO
Fuente de la Lluvia 263
Colonia Balcones de Valle
78280 San Luis Potosí, S.L.P., México

Tel (444) 820 5465
Cel (444) 104 1350
info@omepha-alemania-mexico.com
www.omepha-alemania-mexico.com

Cordless Torque Wrench





The Cordless Torque Wrench LDA/LAW series, 90 – 6,000 N·m

LDA-series

Patented microprocessor-controlled switch-off electronics detect hard and soft tightening operations

Electronic on/off switch for specific control of the bolting operation

Automatic device switch-off when torque achieved. Wrench slackens (backs off) after torque is applied.

Safety function protects the gears and increases the service life of the device



LSupplied with individual LÖSOMAT factory calibration certificate

Powerful 3Ah lithium ion battery, attachable from two sides for easy handling



NEW



Hybrid set optionally available

LAW series





We are showcasing our cordless torque wrenches up to 6,000 N·m

From now on, bolting operations can be implemented independently and flexibly with the LÖSOMAT high-torque cordless torque wrench. It is the first of its kind which can generate precise torques up to 6,000 N·m without slip coupling and impact mechanism.

Applications at great heights or in confined spaces are child's play with the powerful lithium ion battery. Once the battery is fully discharged, you can switch to electrical operation thanks to the optionally available hybrid set (see page 7).

Technische Daten

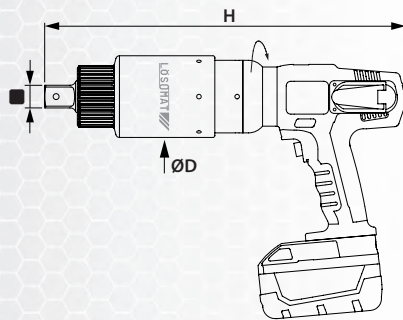

LDA series - straight version

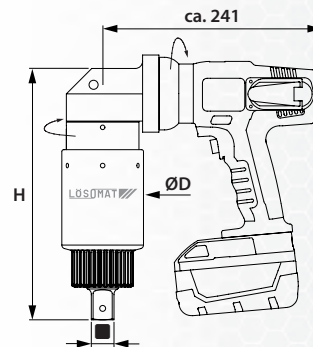

LAW series - angled version

Type	N·m min ^{*1} /max ^{*2}	lbf·ft min ^{*1} /max ^{*2}	~ U/min	■	Ø D mm	H mm	⚖ kg ^{*3}
LDA - 05	90-500	70-370	48	3/4"	80	308	4.2
LDA - 07	120-700	90-520	27	3/4"	80	342	4.7
LDA - 09ST	130-900	100-670	24	3/4"	80	342	4.7
LDA - 15	180-1500	110-1110	20	1"	88	357	5.9
LDA - 16ST	250-2100	180-1550	9	1"	90	375	6.5
LDA - 28ST	350-3100	260-2290	7	1"	90	398	7.2
LDA - 40	430-4000	320-2950	5	1"	94	398	7.5
NEW NEW LDA - 60	650-6000	480-4430	4	1 1/2"	102	412	8.7
LAW - 09ST	130-900	100-670	24	3/4"	80	220	5.9
LAW - 16ST	250-2100	180-1550	9	1"	90	254	7.5
LAW - 28ST	350-3000	260-2200	7	1"	90	277	8.3
NEW LAW - 40	430-4000	320-2950	5	1"	94	277	8.5

^{*1} Lowest torque in 2nd gear

^{*2} Maximum torque in 1st gear

^{*3} Without reaction arm with battery

All rights reserved. Subject to modifications without prior notice.

What makes the cordless torque wrench so powerful?

The secret: the intelligent microprocessor electronics

The heart of the cordless torque wrench is the switch-off electronics with microprocessor control developed and patented by LÖSOMAT.

This allows the tightening torque for each bolting operation to be precisely maintained and ensures stable torque accuracy over the entire discharging cycle of the battery.

In addition, the device detects a wide range of hard and soft bolting operations, automatically adapting to the properties of the bolted connection.

Integrated gear protection and processor-controlled safety

The microprocessor prevents gear damage when loosening hard bolted connections.

The low-backlash gear with a housing made of high-performance aluminium was specially developed further for this series.

An active release function ensures that the wrench automatically releases after work is complete and can thus be easily removed from the bolt.

Lies comfortably in the hand

By shifting the gear centre of gravity, the soft grip of the motor unit lies fatigue-free and non-slip in the hand. The powerful lithium ion battery can be inserted from two sides.

The braked 360°-rotating drive unit prevents any injuries to the operator when used in confined spaces.



The roof structure of the football stadium belonging to TSG 1899 Hoffenheim mounted using LÖSOMAT cordless torque wrenches.

Zubehör



Charger
110V/60Hz; 220V/50Hz



Battery; 28V/3Ah



Voltage transformer for operating the charger in vehicles



Reaction arm cranked with lock on function, made of drop-forged chrome-vanadium steel



Reaction arm made of light alloy, straight with adjustable locking knob with movable square-end and retaining ring.
More information on Page 48.

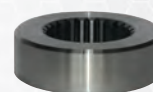

Reaction ring for bespoke reaction arm design



Longer running time with the right battery technology

Technology which makes the work much easier

The lithium ion batteries operate 100% longer in comparison to nickel-cadmium batteries. In addition, they operate with uniform peak performance until they are fully discharged. This saves you having to change the battery frequently while working.

An unbeatable combination

Battery technology and microprocessor electronics supplement each other optimally. The LÖSOMAT microprocessor electronics increases and regulates the battery voltage. This increases the running time of the battery and maintains the torque at a constant level throughout the entire working cycle. This technology has also been patented by LÖSOMAT.



Reserve capacity of battery and charger



The charging time on the charger is approx. 30-50 min when the battery is empty. Once the battery is fully charged, the charger LED changes from red to green



The flashing LED signals that the battery has a reserve capacity of 10%



Lithium ion technology

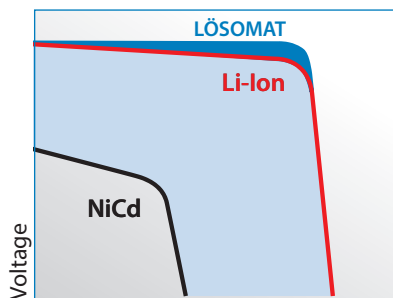

Discharging during work

Four lit up LEDs signal that the battery is fully charged



Pressure switch for displaying the charge status